

LINOVECTOR II

LV3-FT / LV4-FT 14 20 24
Copper/Aluminum and
Steel Element Ratings

Submittal

Specification

LV3 Slip Jointed Enclosure

ENCLOSURE:

STYLE: Flat Top, Top & Front Outlet
OUTLET: Stamped Louvers
Pencil Proof

LENGTHS: 2'0" thru 8'0" in 6" Increments
MAT'L: 16 Ga. CRS (Std)
 14 Ga. CRS (Opt'l)
 16 Ga. Stainless Steel (Opt'l)
 14 Ga. Stainless Steel (Opt'l)
 14 Ga. Aluminum (Opt'l)
 12 Ga. Aluminum (Opt'l)

HEIGHT: 14"
 20" (LV4 only)
 24" (LV4 only)

FINISH: Baked Powder (Std)
 Baked Metallic (Opt'l)

ACCESSORIES:

LV Overlapping Type

All accessories return to the wall at the bottom and have pre-punched holes for fastening to the wall.

LV3-FT14

ELEMENT TUBE SIZE	FIN SIZE HEIGHT x WIDTH	CRADLE NUMBER	A
3/4" COPPER	3 1/4 x 3 1/4	2	7"
1" COPPER	3 1/4 x 3 1/4	2	7 3/16"
1 1/4" COPPER	3 1/4 x 3 1/4	1	6 5/8"
1" STEEL	3 1/4 x 3 1/4	2	7 5/16"
1 1/4" STEEL	3 1/4 x 3 1/4	1	6 13/16"

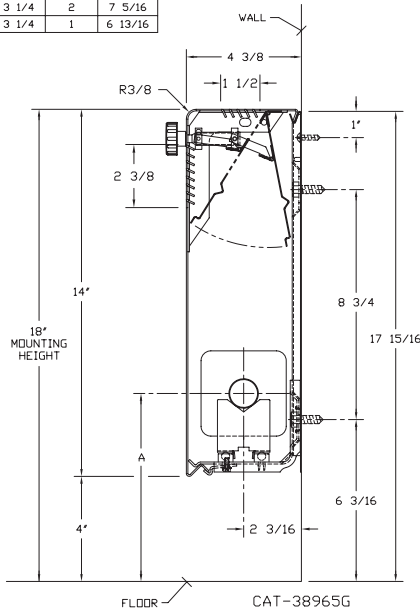

LV4 Slip Jointed Enclosure

BACKPLATE:

TYPE: Partial B/P
LENGTHS: 8'0" Only
MAT'L: 20 Ga. Prepainted (Std)
 18 Ga. Galvannealed (Opt'l)

TYPE: Full Ht. B/P (Opt'l)
LENGTHS: 2'0" thru 8'0" in 6" Increments
MAT'L: 20 Ga. Galvannealed (Opt'l)
 20 Ga. Painted (Opt'l)
 18 Ga. Painted (Opt'l)

AIRSEAL:

1/8" x 3/8" Closed Cell (Opt'l)

BRACKETS:

Water Brkt w/B.B.
 Steam Brkt w/Brkt Mtd
 B.B. Hgr, Bracket Mtd
 B.B. Hgr, Wall Mtd
Wall Mtd B.B. Hgr required for 3rd Tier Element

DAMPER:

Damper Blades Factory Installed
 Knob Damper (Opt'l)
 Tamper Resistant (Opt'l)

LV4-FT14 20 24

ELEMENT TUBE SIZE	FIN SIZE HEIGHT x WIDTH	CRADLE NUMBER	A
3/4" COPPER	3 5/8 x 4 1/4	2	7"
3/4" COPPER	4 1/4 x 4 1/4	3A	7 3/8"
1" COPPER	3 5/8 x 4 1/4	2	7 3/16"
1" COPPER	4 1/4 x 4 1/4	2	7 3/16"
1 1/4" COPPER	3 5/8 x 4 1/4	2	7 5/16"
1 1/4" COPPER	4 1/4 x 4 1/4	2	7 5/16"
1" STEEL	4 1/4 x 4 1/4	2	7 5/16"
1 1/4" STEEL	4 1/4 x 4 1/4	2	7 1/2"
2" STEEL	4 1/4 x 4 1/4	1	7 1/4"

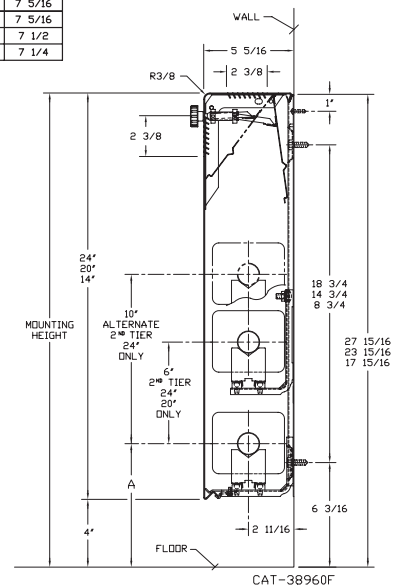

Vulcan

RADIATOR

260 North Elm St., Westfield, MA 01085
(413) 568-9571 Fax: (413) 564-5661
www.vulcanrad.com

PROJECT: _____ DATE: _____

LOCATION: _____

ARCHITECT: _____

ENGINEER: _____

CONTRACTOR: _____

PO NUMBER: _____

STYLE "LV3-FT / LV4-FT 14 20 24" LINOVECTOR II

COPPER/ALUMINUM ELEMENTS

ALL RATINGS ARE IN BTU/HR/LIN FT AND BASED ON 3 FPS VELOCITY, 65° EAT

TUBE SIZE	CATALOG DESIGNATION	FIN SIZE HEIGHT X WIDTH	FINS PER FT.	FIN THICKNESS IN INCHES	ENCL HEIGHT IN INCHES	TIERS AND CENTERS IN INCHES	MOUNTING HEIGHT IN INCHES	STEAM 215° FACTOR	HOT WATER (AVG.)								
									200°	190°	180°	170°	160°	150°	140°	130°	120°
									CORRECTION FACTORS FOR AVERAGE WATER TEMPERATURES								1.00
3/4"	VC3/4-33	3-1/4" SQ.	32	.020	14	1	18	1040	890	810	720	630	550	470	420	340	270
3/4"	VC3/4-34	3-1/4" SQ.	40	.020	14	1	18	1210	1040	940	830	740	640	540	480	400	310
3/4"	VC3/4-35	3-1/4" SQ.	50	.020	14	1	18	1340	1150	1050	920	820	710	600	540	440	350
1"	VC33	3-1/4" SQ.	32	.020	14	1	18	1010	870	790	700	620	540	450	400	330	260
1"	VC34	3-1/4" SQ.	40	.020	14	1	18	1180	1010	920	810	720	630	530	470	390	310
1"	VC35	3-1/4" SQ.	50	.020	14	1	18	1290	1110	1010	890	790	680	580	520	430	340
1 1/4"	VC133	3-1/4" SQ.	32	.020	14	1	18	970	830	760	670	590	510	440	390	320	250
1 1/4"	VC134	3-1/4" SQ.	40	.020	14	1	18	1130	970	880	780	690	600	510	450	370	290
1 1/4"	VC135	3-1/4" SQ.	50	.020	14	1	18	1250	1080	980	860	760	660	560	500	410	330
3/4"	VC3/4-433	3-5/8" x 4-1/4"	32	.020	14	1	18	1440	1240	1120	990	880	760	650	580	480	370
					20	1	24	1520	1310	1190	1050	930	810	680	610	500	400
					20	2-6 CL	24	2150	1850	1680	1480	1310	1140	970	860	710	560
					24	1	28	1560	1340	1220	1080	950	830	700	620	510	410
					24	2-6 CL	28	2230	1920	1740	1540	1360	1180	1000	890	740	580
24	3-6 CL	28	2560	2200	2000	1770	1560	1360	1150	1020	840	670					
3/4"	VC3/4-434	3-5/8" x 4-1/4"	40	.020	14	1	18	1620	1390	1260	1120	990	860	730	650	530	420
					20	1	24	1700	1460	1330	1170	1040	900	770	680	560	440
					20	2-6 CL	24	2410	2070	1880	1660	1470	1280	1080	960	800	630
					24	1	28	1740	1500	1360	1200	1060	920	780	700	570	450
					24	2-6 CL	28	2490	2140	1940	1720	1520	1320	1120	1000	820	650
24	3-6 CL	28	2840	2440	2220	1960	1730	1510	1280	1140	940	740					
3/4"	VC3/4-435	3-5/8" x 4-1/4"	50	.020	14	1	18	1770	1520	1380	1220	1080	940	800	710	580	460
					20	1	24	1920	1650	1500	1320	1170	1020	860	770	630	500
					20	2-6 CL	24	2680	2300	2090	1850	1630	1420	1210	1070	880	700
					24	1	28	1990	1710	1550	1370	1210	1050	900	800	660	520
					24	2-6 CL	28	2860	2460	2230	1970	1740	1520	1290	1140	940	740
24	3-6 CL	28	3230	2780	2520	2230	1970	1710	1450	1290	1070	840					
1"	VC433	3-5/8" x 4-1/4"	32	.020	14	1	18	1460	1260	1140	1010	890	770	660	580	480	380
					20	1	24	1520	1310	1190	1050	930	810	680	610	500	400
					20	2-6 CL	24	2320	2000	1810	1600	1420	1230	1040	930	770	600
					24	1	28	1570	1350	1220	1080	960	830	710	630	520	410
					24	2-6 CL	28	2380	2050	1860	1640	1450	1260	1070	950	790	620
24	3-6 CL	28	2740	2360	2140	1890	1670	1450	1230	1100	900	710					
1"	VC434	3-5/8" x 4-1/4"	40	.020	14	1	18	1670	1440	1300	1150	1020	890	750	670	550	430
					20	1	24	1780	1530	1390	1230	1090	940	800	710	590	460
					20	2-6 CL	24	2490	2140	1940	1720	1520	1320	1120	1000	820	650
					24	1	28	1820	1570	1420	1260	1110	960	820	730	600	470
					24	2-6 CL	28	2570	2210	2000	1770	1570	1360	1160	1030	850	670
24	3-6 CL	28	2930	2520	2290	2020	1790	1550	1320	1170	970	760					
1"	VC435	3-5/8" x 4-1/4"	50	.020	14	1	18	1860	1600	1450	1280	1130	990	840	740	610	480
					20	1	24	2010	1730	1570	1390	1230	1070	900	800	660	520
					20	2-6 CL	24	2510	2160	1960	1730	1530	1330	1130	1000	830	650
					24	1	28	2080	1790	1620	1440	1270	1100	940	830	690	540
					24	2-6 CL	28	2680	2300	2090	1850	1630	1420	1210	1070	880	700
24	3-6 CL	28	3030	2610	2360	2090	1850	1610	1360	1210	1000	790					
1-1/4"	VC1433	3-5/8" x 4-1/4"	32	.020	14	1	18	1430	1230	1120	990	870	760	640	570	470	370
					20	1	24	1490	1280	1160	1030	910	790	670	600	490	390
					20	2 @ 6 CL	24	2280	1960	1780	1570	1390	1210	1030	910	750	590
					24	1	28	1540	1320	1200	1060	940	820	690	620	510	400
					24	2 @ 6 CL	28	2340	2010	1830	1610	1430	1240	1050	940	770	610
24	3 @ 6 CL	28	2690	2310	2100	1860	1640	1430	1210	1080	890	700					
1-1/4"	VC1434	3-5/8" x 4-1/4"	40	.020	14	1	18	1630	1400	1270	1120	990	860	730	650	540	420
					20	1	24	1740	1500	1360	1200	1060	920	780	700	570	450
					20	2 @ 6 CL	24	2440	2100	1900	1680	1490	1290	1100	980	810	630
					24	1	28	1780	1530	1390	1230	1090	940	800	710	590	460
					24	2 @ 6 CL	28	2520	2170	1970	1740	1540	1340	1130	1010	830	660
24	3 @ 6 CL	28	2870	2470	2240	1980	1750	1520	1290	1150	950	750					
1-1/4"	VC1435	3-5/8" x 4-1/4"	50	.020	14	1	18	1820	1570	1420	1260	1110	960	820	730	600	470
					20	1	24	1970	1690	1540	1360	1200	1040	890	790	650	510
					20	2 @ 6 CL	24	2460	2120	1920	1700	1500	1300	1110	980	810	640
					24	1	28	2040	1750	1590	1410	1240	1080	920	820	670	530
					24	2 @ 6 CL	28	2620	2250	2040	1810	1600	1390	1180	1050	860	680
24	3 @ 6 CL	28	2960	2550	2310	2040	1810	1570	1330	1180	980	770					

STYLE "LV3-FT / LV4-FT 14 20 24" LINOVECTOR II

COPPER/ALUMINUM ELEMENTS

ALL RATINGS ARE IN BTU/HR/LIN FT AND BASED ON 3 FPS VELOCITY, 65° EAT

TUBE SIZE	CATALOG DESIGNATION	FIN SIZE HEIGHT X WIDTH	FINS PER FT.	FIN THICKNESS IN INCHES	ENCL HEIGHT IN INCHES	TIERS AND CENTERS IN INCHES	MOUNTING HEIGHT IN INCHES	STEAM 215° FACTOR	HOT WATER (AVG.)								
									200°	190°	180°	170°	160°	150°	140°	130°	120°
									CORRECTION FACTORS FOR AVERAGE WATER TEMPERATURES								
3/4"	VC3/4-43	4-1/4" SQ.	32	.020	14	1	18	1460	1260	1140	1010	890	770	660	580	480	380
					20	1	24	1540	1320	1200	1060	940	820	690	620	510	400
					20	2-6 CL	24	2360	2030	1840	1630	1440	1250	1060	940	780	610
					24	1	28	1570	1350	1220	1080	960	830	710	630	520	410
					24	2-6 CL	28	2440	2100	1900	1680	1490	1290	1100	980	810	630
24	3-6 CL	28	2810	2420	2190	1940	1710	1490	1260	1120	930	730					
3/4"	VC3/4-44	4-1/4" SQ.	40	.020	14	1	18	1850	1590	1440	1280	1130	980	830	740	610	480
					20	1	24	2080	1790	1620	1440	1270	1100	940	830	690	540
					20	2-6 CL	24	2500	2150	1950	1720	1530	1330	1130	1000	830	650
					24	1	28	2120	1820	1650	1460	1290	1120	950	850	700	550
					24	2-6 CL	28	2650	2280	2070	1830	1620	1400	1190	1060	870	690
24	3-6 CL	28	3020	2600	2360	2080	1840	1600	1360	1210	1000	790					
3/4"	VC3/4-45	4-1/4" SQ.	50	.020	14	1	18	1815	1560	1420	1250	1110	960	820	730	600	470
					20	1	24	1970	1690	1540	1360	1200	1040	890	790	650	510
					20	2-6 CL	24	2565	2210	2000	1770	1560	1360	1150	1030	850	670
					24	1	28	2040	1750	1590	1410	1240	1080	920	820	670	530
					24	2-6 CL	28	2795	2400	2180	1930	1700	1480	1260	1120	920	730
24	3-6 CL	28	3160	2720	2460	2180	1930	1670	1420	1260	1040	820					
1"	VC43	4-1/4" SQ.	32	.020	14	1	18	1620	1390	1260	1120	990	860	730	650	530	420
					20	1	24	1660	1430	1290	1150	1010	880	750	660	550	430
					20	2-6 CL	24	2460	2120	1920	1700	1500	1300	1110	980	810	640
					24	1	28	1690	1450	1320	1170	1030	900	760	680	560	440
					24	2-6 CL	28	2510	2160	1960	1730	1530	1330	1130	1000	830	650
24	3-6 CL	28	2890	2490	2250	1990	1760	1530	1300	1160	950	750					
1"	VC44	4-1/4" SQ.	40	.020	14	1	18	1760	1510	1370	1210	1070	930	790	700	580	460
					20	1	24	1940	1670	1510	1340	1180	1030	870	780	640	500
					20	2-6 CL	24	2560	2200	2000	1770	1560	1360	1150	1020	840	670
					24	1	28	2010	1730	1570	1390	1230	1070	900	800	660	520
					24	2-6 CL	28	2700	2320	2110	1860	1650	1430	1220	1080	890	700
24	3-6 CL	28	3080	2650	2400	2130	1880	1630	1390	1230	1020	800					
1"	VC45	4-1/4" SQ.	50	.020	14	1	18	1900	1630	1480	1310	1160	1010	860	760	630	490
					20	1	24	2120	1820	1650	1460	1290	1120	950	850	700	550
					20	2-6 CL	24	2550	2190	1990	1760	1560	1350	1150	1020	840	660
					24	1	28	2220	1910	1730	1530	1350	1180	1000	890	730	580
					24	2-6 CL	28	2730	2350	2130	1880	1670	1450	1230	1090	900	710
24	3-6 CL	28	3080	2650	2400	2130	1880	1630	1390	1230	1020	800					
1-1/4"	VC143	4-1/4" SQ.	32	.020	14	1	18	1590	1370	1240	1100	970	840	720	640	520	410
					20	1	24	1630	1400	1270	1120	990	860	730	650	540	420
					20	2-6 CL	24	2420	2080	1890	1670	1480	1280	1090	970	800	630
					24	1	28	1660	1430	1290	1150	1010	880	750	660	550	430
					24	2-6 CL	28	2470	2120	1930	1700	1510	1310	1110	990	820	640
24	3-6 CL	28	2840	2440	2220	1960	1730	1510	1280	1140	940	740					
1-1/4"	VC144	4-1/4" SQ.	40	.020	14	1	18	1730	1490	1350	1190	1060	920	780	690	570	450
					20	1	24	1900	1630	1480	1310	1160	1010	860	760	630	490
					20	2-6 CL	24	2510	2160	1960	1730	1530	1330	1130	1000	830	650
					24	1	28	1970	1690	1540	1360	1200	1040	890	790	650	510
					24	2-6 CL	28	2660	2290	2070	1840	1620	1410	1200	1060	880	690
24	3-6 CL	28	3030	2610	2360	2090	1850	1610	1360	1210	1000	790					
1-1/4"	VC145	4-1/4" SQ.	50	.020	14	1	18	1860	1600	1450	1280	1130	990	840	740	610	480
					20	1	24	2080	1790	1620	1440	1270	1100	940	830	690	540
					20	2-6 CL	24	2510	2160	1960	1730	1530	1330	1130	1000	830	650
					24	1	28	2190	1880	1710	1510	1340	1160	990	880	720	570
					24	2-6 CL	28	2680	2300	2090	1850	1630	1420	1210	1070	880	700
24	3-6 CL	28	3030	2610	2360	2090	1850	1610	1360	1210	1000	790					

Note: Copper tube furnished flared one end standard.

STYLE "LV3-FT / LV4-FT 14 20 24" LINOVECTOR II

STEEL ELEMENTS

ALL RATINGS ARE IN BTU/HR/LIN FT AND BASED ON 3 FPS VELOCITY, 65° EAT

TUBE SIZE	CATALOG DESIGNATION	FIN SIZE HEIGHT X WIDTH	FINS PER FT.	FIN THICKNESS IN INCHES	ENCL HEIGHT IN INCHES	TIERS AND CENTERS IN INCHES	MOUNTING HEIGHT IN INCHES	STEAM 215° FACTOR	HOT WATER (AVG.)								
									200°	190°	180°	170°	160°	150°	140°	130°	120°
									CORRECTION FACTORS FOR AVERAGE WATER TEMPERATURES								
1"	VS33	3-1/4" SQ.	32	.032	14	1	18	920	0.86	0.78	0.69	0.61	0.53	0.45	.40	.33	.26
1"	VS34	3-1/4" SQ.	40	.032	14	1	18	1000	860	780	690	610	530	450	400	330	260
1"	VS35	3-1/4" SQ.	50	.032	14	1	18	1070	920	830	740	650	570	480	430	350	280
1-1/4"	VS133	3-1/4" SQ.	32	.032	14	1	18	910	780	710	630	560	480	410	360	300	240
1-1/4"	VS134	3-1/4" SQ.	40	.032	14	1	18	1030	890	800	710	630	550	460	410	340	270
1-1/4"	VS135	3-1/4" SQ.	50	.032	14	1	18	1060	910	830	730	650	560	480	420	350	280
1"	VS43	4-1/4" SQ.	32	.032	14	1	18	1300	1120	1010	900	790	690	590	520	430	340
					20	1	24	1355	1170	1060	930	830	720	610	540	450	350
					20	2-6 CL	24	2030	1750	1580	1400	1240	1080	910	810	670	530
					24	1	28	1460	1260	1140	1010	890	770	660	580	480	380
					24	2-6 CL	28	2095	1800	1630	1450	1280	1110	940	840	690	540
1"	VS44	4-1/4" SQ.	40	.032	14	1	18	1455	1250	1130	1000	890	770	650	580	480	380
					20	1	24	1550	1330	1210	1070	950	820	700	620	510	400
					20	2-6 CL	24	2195	1890	1710	1510	1340	1160	990	880	720	570
					24	1	28	1605	1380	1250	1110	980	850	720	640	530	420
					24	2-6 CL	28	2295	1970	1790	1580	1400	1220	1030	920	760	600
1"	VS45	4-1/4" SQ.	50	.032	14	1	18	1525	1310	1190	1050	930	810	690	610	500	400
					20	1	24	1620	1390	1260	1120	990	860	730	650	530	420
					20	2-6 CL	24	2245	1930	1750	1550	1370	1190	1010	900	740	580
					24	1	28	1680	1440	1310	1160	1020	890	760	670	550	440
					24	2-6 CL	28	2350	2020	1830	1620	1430	1250	1060	940	780	610
1-1/4"	VS143	4-1/4" SQ.	32	.032	14	1	18	1190	1020	930	820	730	630	540	480	390	310
					20	1	24	1220	1050	950	840	740	650	550	490	400	320
					20	2-6 CL	24	1910	1640	1490	1320	1170	1010	860	760	630	500
					24	1	28	1240	1070	970	860	760	660	560	500	410	320
					24	2-6 CL	28	1940	1670	1510	1340	1180	1030	870	780	640	500
1-1/4"	VS144	4-1/4" SQ.	40	.032	14	1	18	1510	1300	1180	1040	920	800	680	600	500	390
					20	1	24	1600	1380	1250	1100	980	850	720	640	530	420
					20	2-6 CL	24	2330	2000	1820	1610	1420	1230	1050	930	770	610
					24	1	28	1660	1430	1290	1150	1010	880	750	660	550	430
					24	2-6 CL	28	2410	2070	1880	1660	1470	1280	1080	960	800	630
1-1/4"	VS145	4-1/4" SQ.	50	.032	14	1	18	1515	1300	1180	1050	920	800	680	610	500	390
					20	1	24	1610	1380	1260	1110	980	850	720	640	530	420
					20	2-6 CL	24	2200	1890	1720	1520	1340	1170	990	880	730	570
					24	1	28	1670	1440	1300	1150	1020	890	750	670	550	430
					24	2-6 CL	28	2305	1980	1800	1590	1410	1220	1040	920	760	600
2"	VS242	4-1/4" SQ.	25	.032	14	1	18	1160	1000	900	800	710	610	520	460	380	300
					20	1	24	1190	1020	930	820	730	630	540	480	390	310
					20	2-6 CL	24	1870	1610	1460	1290	1140	990	840	750	620	490
					24	1	28	1210	1040	940	830	740	640	540	480	400	310
					24	2-6 CL	28	1920	1650	1500	1320	1170	1020	860	770	630	500
2"	VS243	4-1/4" SQ.	32	.032	14	1	18	1350	1160	1050	930	820	720	610	540	450	350
					20	1	24	1400	1200	1090	970	850	740	630	560	460	360
					20	2-6 CL	24	2090	1800	1630	1440	1270	1110	940	840	690	540
					24	1	28	1430	1230	1120	990	870	760	640	570	470	370
					24	2-6 CL	28	2160	1860	1680	1490	1320	1140	970	860	710	560
2"	VS243	4-1/4" SQ.	32	.032	14	1	18	2480	2130	1930	1710	1510	1310	1120	990	820	640
					20	1	24	1350	1160	1050	930	820	720	610	540	450	350
					20	2-6 CL	24	2090	1800	1630	1440	1270	1110	940	840	690	540
					24	1	28	1430	1230	1120	990	870	760	640	570	470	370
					24	2-6 CL	28	2160	1860	1680	1490	1320	1140	970	860	710	560

- Notes: 1) Steel fins furnished as .032 thick, painted black.
 2) NPT threads furnished on steel elements. Please use domestic fittings for proper installation.
 3) The ends can be provided chamfered for field welded fittings when specified.

Steam Bracket and BB Hanger

ELEMENT TUBE SIZE	FIN SIZE HEIGHT x WIDTH	CRADLE NUMBER	A MIN	A MAX
3/4 COPPER	3 1/4 x 3 1/4	2	7 3/8	9 5/8
1" COPPER	3 1/4 x 3 1/4	2	7 1/2	9 3/4
1 1/4 COPPER	3 1/4 x 3 1/4	1	7"	9 1/16
1" STEEL	3 1/4 x 3 1/4	2	7 5/8	9 3/4
1 1/4 STEEL	3 1/4 x 3 1/4	1	7 3/16	9 3/8

ELEMENT TUBE SIZE	FIN SIZE HEIGHT x WIDTH	CRADLE NUMBER	A MIN	A MAX
3/4 COPPER	3 5/8 x 4 1/4	2	7 3/8	8 3/4
	4 1/4 x 4 1/4	3A	7 11/16	9 1/16
1" COPPER	3 5/8 x 4 1/4	2	7 1/2	8 7/8
	4 1/4 x 4 1/4			
1 1/4 COPPER	3 5/8 x 4 1/4	2	7 5/8	9"
	4 1/4 x 4 1/4			
1" STEEL	4 1/4 x 4 1/4	2	7 5/8	9"
1 1/4 STEEL	4 1/4 x 4 1/4	2	7 7/8	9 1/4
2" STEEL	4 1/4 x 4 1/4	1	7 5/8	9"

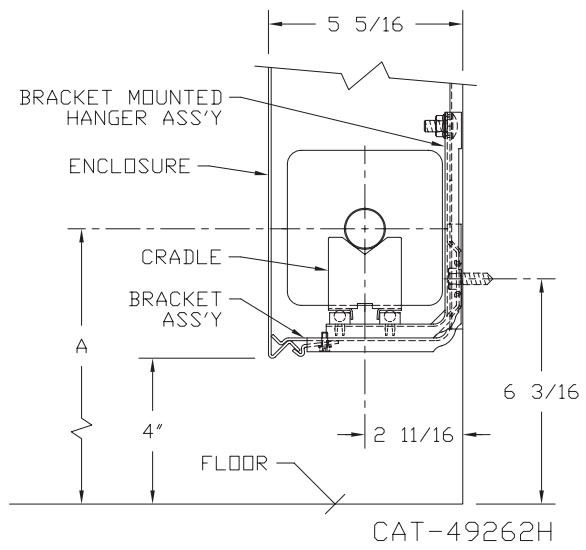
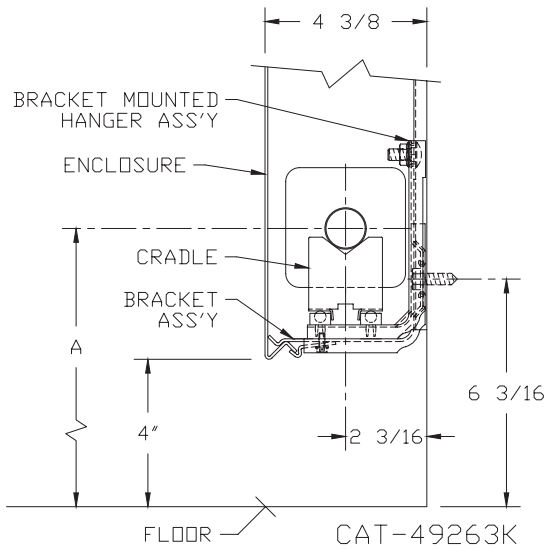

Design Data

COMMERCIAL FINNED TUBE CHARTS FOR RATING CORRECTIONS

For assistance with ratings and selection, please use our online Specifier.

CORRECTION FACTORS FOR WATER TEMPERATURES AND AIR TEMPERATURES OTHER THAN STANDARD															
AVERAGE WATER TEMP. °F	ENTERING AIR TEMPERATURE °F														
	45	55	STD 65	70	75	80	85	90	95	100	110	120	130	140	150
90	.19	.13	.11	.06											
100	.25	.19	.15	.11	.08	.06									
110	.31	.25	.20	.16	.13	.11	.08	.06							
120	.38	.31	.26	.21	.19	.16	.13	.11	.08	.06					
130	.45	.38	.33	.28	.25	.21	.19	.16	.13	.11	.06				
140	.53	.45	.40	.34	.31	.28	.25	.21	.19	.16	.11	.06			
150	.61	.53	.45	.41	.38	.34	.31	.28	.25	.21	.16	.11	.06		
160	.69	.61	.53	.49	.45	.41	.38	.34	.31	.28	.21	.16	.11	.06	
170	.77	.69	.61	.57	.53	.49	.45	.41	.38	.34	.28	.21	.16	.11	.06
180	.86	.77	.69	.65	.61	.57	.53	.49	.45	.41	.34	.28	.21	.16	.11
190	.95	.86	.78	.73	.69	.65	.61	.57	.53	.49	.41	.34	.28	.21	.16
200	1.05	.95	.86	.82	.77	.73	.69	.65	.61	.57	.49	.41	.34	.28	.21
210	1.14	1.05	.95	.91	.86	.82	.77	.73	.69	.65	.57	.49	.41	.34	.28
▶ 215 (STD.)	1.19	1.09	1.00	.95	.91	.86	.82	.77	.73	.69	.61	.53	.45	.38	.31
220	1.24	1.14	1.05	1.00	.95	.91	.86	.82	.77	.73	.65	.57	.49	.41	.34
230	1.34	1.24	1.14	1.09	1.05	1.00	.95	.91	.86	.82	.73	.65	.57	.49	.41
240	1.44	1.34	1.25	1.19	1.14	1.09	1.05	1.00	.95	.91	.82	.73	.65	.57	.49
250	1.55	1.44	1.34	1.29	1.24	1.19	1.14	1.09	1.05	1.00	.91	.82	.73	.65	.57
260	1.66	1.55	1.44	1.39	1.34	1.29	1.24	1.19	1.14	1.09	1.00	.91	.82	.73	.65
270	1.76	1.66	1.55	1.50	1.44	1.39	1.34	1.29	1.24	1.19	1.09	1.00	.91	.82	.73
280	1.87	1.76	1.66	1.60	1.55	1.50	1.44	1.39	1.34	1.29	1.19	1.09	1.00	.91	.82
290	1.99	1.87	1.76	1.71	1.66	1.60	1.55	1.50	1.44	1.39	1.29	1.19	1.09	1.00	.91
300	2.10	1.99	1.87	1.82	1.76	1.71	1.66	1.60	1.55	1.50	1.39	1.29	1.19	1.09	1.00

CORRECTION FACTORS FOR STEAM PRESSURES AND AIR TEMPERATURES OTHER THAN STANDARD																
STEAM		ENTERING AIR TEMPERATURE °F														
PRESSURE		TEMP. °F	45	55	STD 65	70	75	80	85	90	100	110	120	130	140	150
GAUGE	ABS. PSI															
(VAC) 15" HG	7.32	178.9	0.90	0.80	0.70	0.65	0.60	0.56	0.51	0.45	0.39	0.32	0.25	0.18	0.13	0.08
(VAC) 10"	9.78	192.2	1.02	0.91	0.81	0.76	0.71	0.66	0.62	0.55	0.48	0.40	0.33	0.26	0.20	0.14
(VAC) 5"	12.25	202.9	1.11	1.00	0.90	0.85	0.79	0.75	0.70	0.63	0.56	0.48	0.40	0.33	0.27	0.20
▶ 0 PSI	14.696	212.0	1.19	1.09	0.97	0.92	0.87	0.82	0.77	0.70	0.63	0.54	0.46	0.38	0.31	0.25
.899	15.595	215.0	1.22	1.11	1.00	0.95	0.90	0.84	0.80	0.75	0.65	0.57	0.48	0.40	0.33	0.26
5	19.70	227.1	1.34	1.22	1.11	1.05	1.00	0.95	0.90	0.81	0.75	0.66	0.57	0.49	0.41	0.34
10	24.70	239.4	1.45	1.33	1.22	1.17	1.11	1.05	1.00	0.91	0.85	0.75	0.66	0.58	0.50	0.42
15	29.70	249.8	1.55	1.43	1.31	1.26	1.20	1.14	1.09	1.00	0.94	0.84	0.75	0.66	0.57	0.49
20	34.70	258.5	1.63	1.52	1.40	1.33	1.28	1.23	1.17	1.07	1.02	0.92	0.82	0.73	0.64	0.55
25	39.70	266.8	1.71	1.59	1.47	1.41	1.36	1.30	1.25	1.15	1.09	0.98	0.89	0.80	0.71	0.62
30	44.70	274.0	1.78	1.66	1.54	1.48	1.42	1.37	1.31	1.21	1.15	1.05	0.95	0.85	0.76	0.68
40	54.70	286.7	1.91	1.79	1.66	1.61	1.54	1.49	1.43	1.32	1.27	1.16	1.06	0.97	0.87	0.78
50	64.70	297.7	2.02	1.90	1.77	1.71	1.65	1.60	1.54	1.42	1.37	1.26	1.16	1.06	0.96	0.87
60	74.70	307.3	2.10	2.00	1.87	1.81	1.75	1.69	1.63	1.51	1.47	1.35	1.25	1.15	1.05	0.95
70	84.70	316.0	2.20	2.09	1.95	1.89	1.83	1.77	1.71	1.59	1.55	1.44	1.33	1.23	1.12	1.03
80	94.70	323.9	2.27	2.17	2.03	1.97	1.91	1.85	1.80	1.69	1.63	1.52	1.41	1.31	1.20	1.10
90	104.70	331.2	2.36	2.24	2.11	2.05	1.98	1.93	1.87	1.74	1.70	1.59	1.48	1.38	1.28	1.17
100	114.70	337.9	2.43	2.31	2.18	2.11	2.05	2.00	1.94	1.81	1.77	1.65	1.54	1.44	1.33	1.23
125	139.70	352.9	2.59	2.47	2.33	2.27	2.21	2.16	2.10	1.96	1.92	1.80	1.69	1.59	1.48	1.38
150	164.70	365.9	2.73	2.62	2.47	2.43	2.35	2.29	2.23	2.08	2.05	1.94	1.82	1.72	1.61	1.51
175	189.70	377.4	2.86	2.74	2.60	2.54	2.47	2.41	2.35	2.21	2.17	2.05	1.95	1.85	1.73	1.63
200	214.70	387.8	2.95	2.85	2.71	2.63	2.58	2.52	2.47	2.31	2.29	2.17	2.06	1.96	1.84	1.75

From Keenan and Keyes — Linear Interpolation. NOTE: Gauge pressure should be corrected for altitude.

Rate of pitch for steam 1/2" drop over 20-foot run.

Design Data

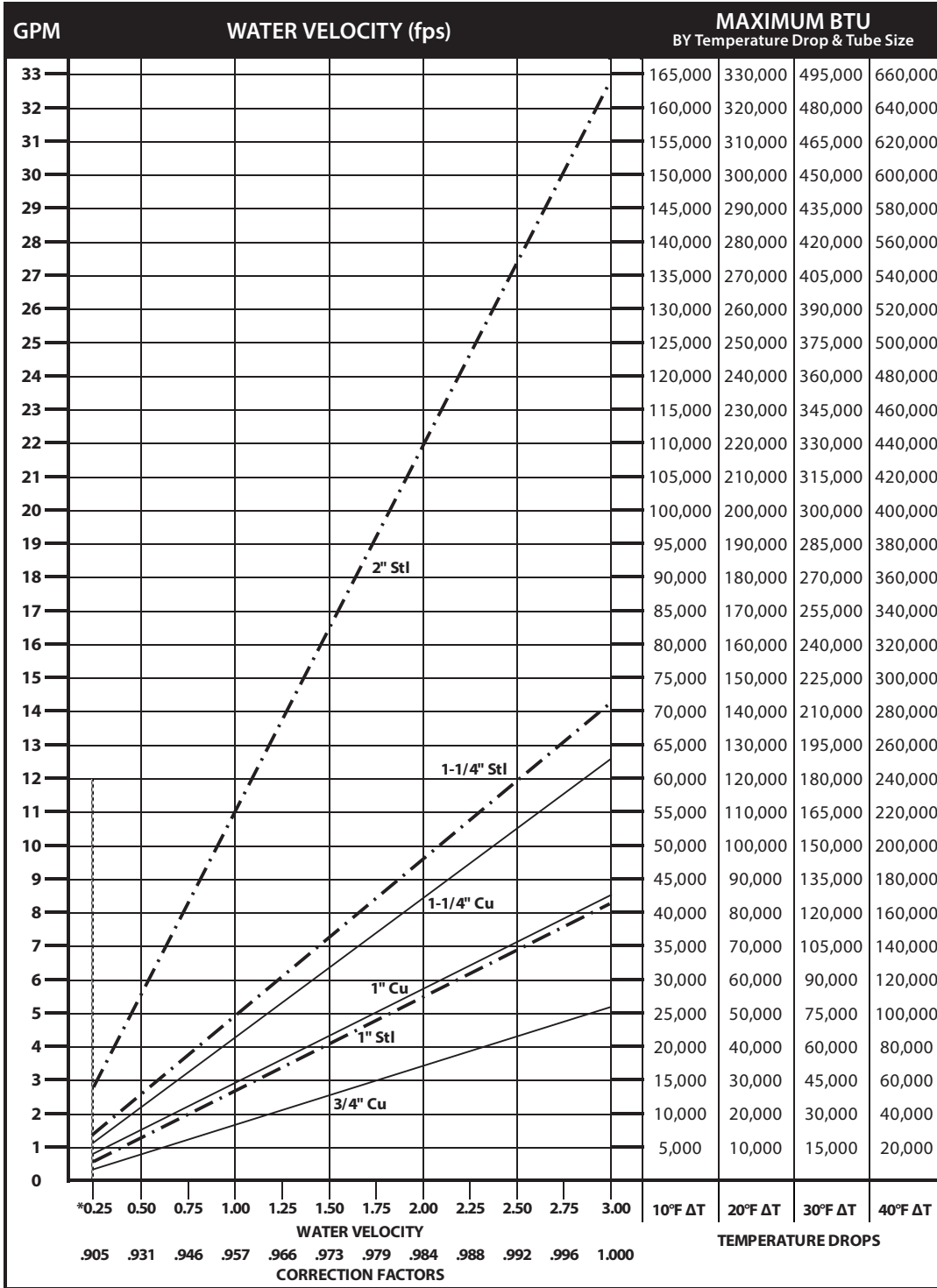

DYNAMIC FORMULAS

$$\text{BTU} = \text{GPM} \times 500 \times \text{TD}$$

$$\text{GPM} = \left(\frac{\text{BTU}}{500} \right) \div \text{TD}$$

$$\text{TD} = \left(\frac{\text{BTU}}{500} \right) \div \text{GPM}$$

*Do not design below .25 fps.

Pressure Drop at Given Water Velocities (Feet of Water per 100 ft. of pipe) based on Hazen - Williams calculation

Nominal Pipe Size	Water Velocity (ft/sec)											
	0.25	0.50	0.75	1.00	1.25	1.50	1.75	2.00	2.25	2.50	2.75	3.00
3/4" Copper	0.06	0.20	0.42	0.72	1.09	1.53	2.04	2.61	3.25	3.95	4.71	5.53
1" Copper	0.04	0.15	0.32	0.54	0.81	1.14	1.52	1.94	2.42	2.94	3.50	4.11
1 1/4" Copper	0.03	0.12	0.25	0.43	0.64	0.90	1.20	1.54	1.92	2.33	2.78	3.26
1" Steel	0.04	0.15	0.32	0.54	0.81	1.14	1.52	1.95	2.42	2.94	3.51	4.12
1 1/4" Steel	0.03	0.11	0.23	0.40	0.60	0.84	1.12	1.44	1.79	2.17	2.59	3.05
2" Steel	0.02	0.07	0.14	0.25	0.37	0.52	0.69	0.89	1.10	1.34	1.60	1.88

Design Data

GUARANTEED WORKING PRESSURES

- 1" IPS — 780 at Temperatures up to 650°F.
- 1-1/4" IPS — 660 at Temperatures up to 650°F.
- 2" IPS — 405 at Temperatures up to 650°F.
- 1-1/4" CU — 194 at Temperatures up to 300°F.
- 1" CU 204 at Temperatures up to 300°F.
- 3/4" CU 218 PSI at Temperatures up to 300°F.

MAXIMUM PRESSURES AT OTHER TEMPERATURES ARE AVAILABLE UPON REQUEST.

Pipe Water Capacities and Quantities Circulated at Velocity of 3 Feet Per Second

Nominal Pipe Size	Pipe I.D. (inches)	Gals Per Lin. Ft.	GPM @ 3' per sec Velocity
3/4" Copper	0.835	0.028	5.12
1" Copper	1.077	0.047	8.52
1 1/4" Copper	1.315	0.071	12.70
1" Steel	1.075	0.047	8.49
1 1/4" Steel	1.395	0.079	14.29
2" Steel	2.115	0.183	32.85

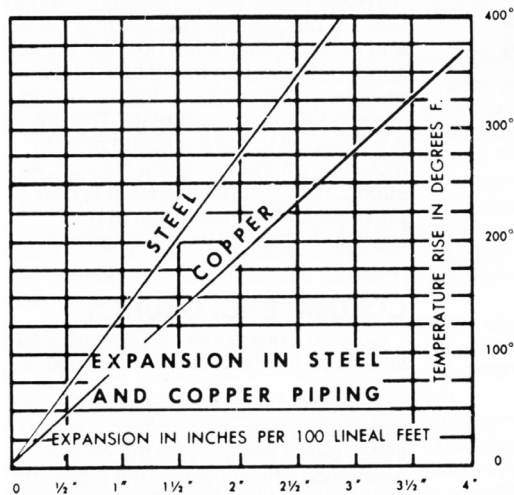

Glycol Correction Factors

Fluid Temperature 200°F

% Solution	Ethylene Glycol	Propylene Glycol
20	.952	.988
30	.921	.968
40	.888	.943
50	.852	.912

Fluid Temperature 180°F

% Solution	Ethylene Glycol	Propylene Glycol
20	.946	.982
30	.913	.961
40	.879	.934
50	.842	.902

Fluid Temperature 140°F

% Solution	Ethylene Glycol	Propylene Glycol
20	.934	.97
30	.898	.946
40	.861	.916
50	.821	.881

INLET VS. OUTPUT/BTUH CAPACITY REDUCTION

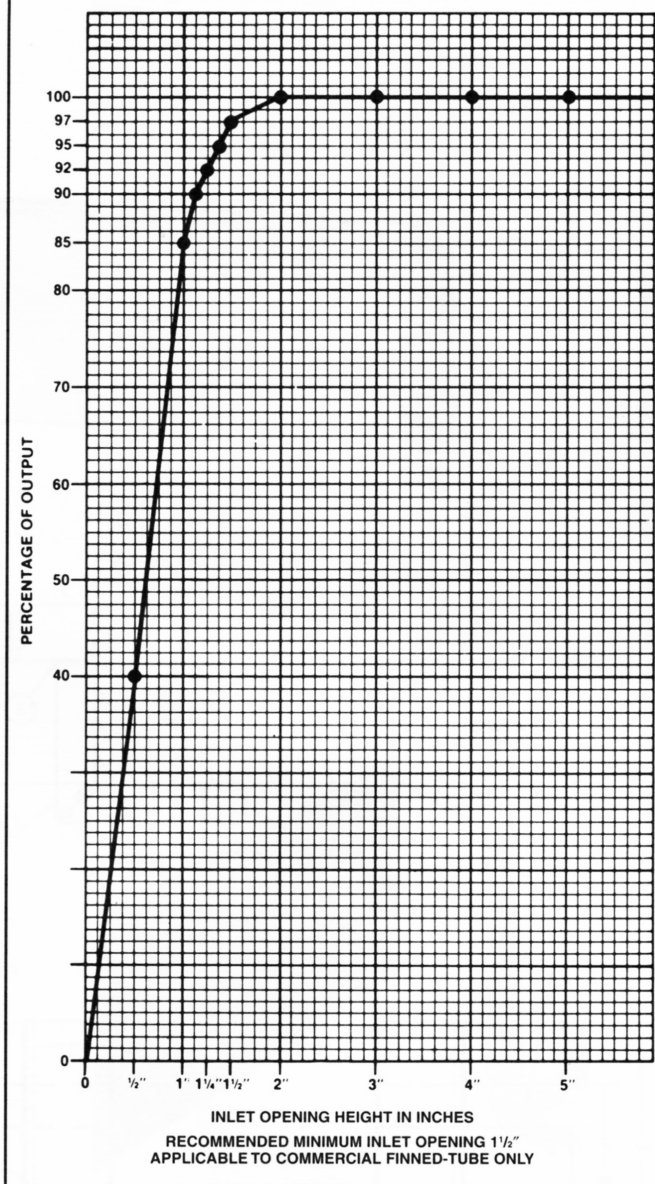

ALTITUDE FACTORS

Approximate factors for convective heat value at varying altitudes

Altitude	Ferrous Units	Copper Alum. Units
Sea Level	1.000	1,000
1,000 ft.	.984	.969
2,000 ft.	.968	.938
3,000 ft.	.952	.908
4,000 ft.	.936	.878
5,000 ft.	.920	.850
6,000 ft.	.904	.822
7,000 ft.	.889	.795
8,000 ft.	.874	.768
9,000 ft.	.859	.743
10,000 ft.	.844	.718
15,000 ft.	.771	.603
20,000 ft.	.703	.502